

BS

Shear Beam Load Cell

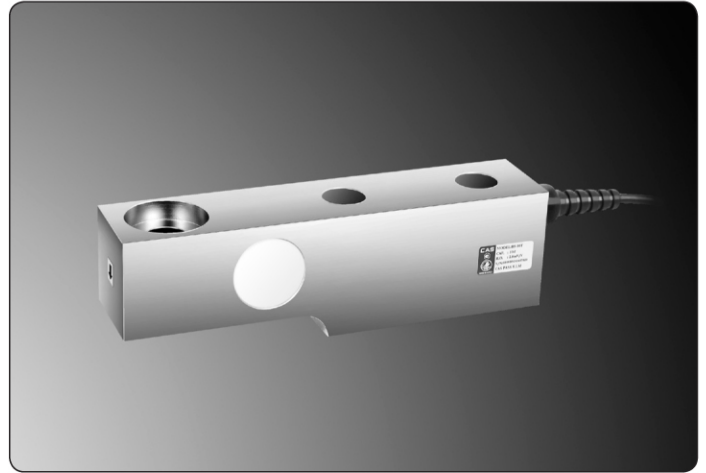

LOAD CELL

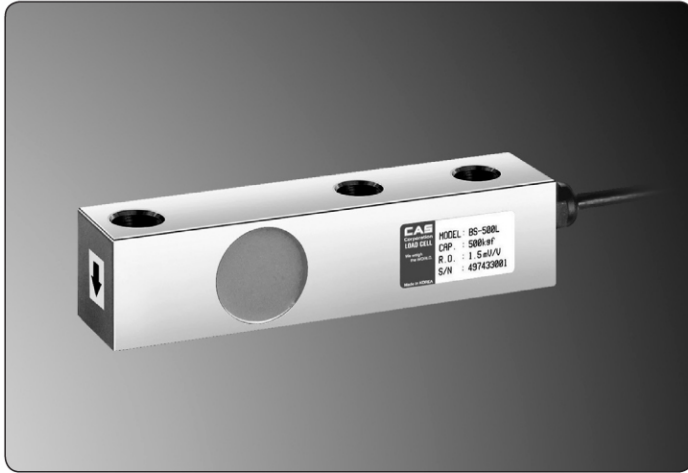

FEATURES

- Low price high accuracy
- Protection Class IP65

ACCESSORY OPTION

- Ballcup type accessory

050-2222-9933

SPECIFICATION

Max. Capacity (Rated Load)	kgf	250, 500	1K, 2K, 3K, 5K, 10K
Rated Output	mV / V	1.5 ± 0.0037	2.0 ± 0.005
Zero Balance	mV / V	0.0 ± 0.015	0.0 ± 0.02
Accuracy Class	-	-	
Non-Linearity	% R.O.	0.03	
Hysteresis	% R.O.	0.03	
Combined Error	% R.O.	0.03	
Repeatability	% R.O.	0.01	
Creep for 30min.	% R.O.	0.03	
Return for 30min.	% R.O.	0.03	
Resolution	-	≤1/3000	
Division	mV / V	0.0005	0.00067
Temperature Effect on	-	-	
_Zero Value	% / 10°C	0.028	
_Output Value	% / 10°C	0.015	
Excitation	-	-	
_Recommended	V	10	
_Maximum	V	15	
Resistance	-	-	
_Input	Ω	400 ± 20	
_Output	Ω	350 ± 5	
_Insulation	MΩ	>2000	
Compensated Temperature Range	°C	-10 to +40	
Operating Temperature Range	°C	-20 to +80	
Material & Plate	-	Nikel Plated Steel	
Cable Specification	-	ø5.4 x 4p x 3M (Urethane)	
Safety Overload	%R.L.	150	
Platform Size	mm	Without Limit	

BS

Shear Beam Load Cell



DIMENSION

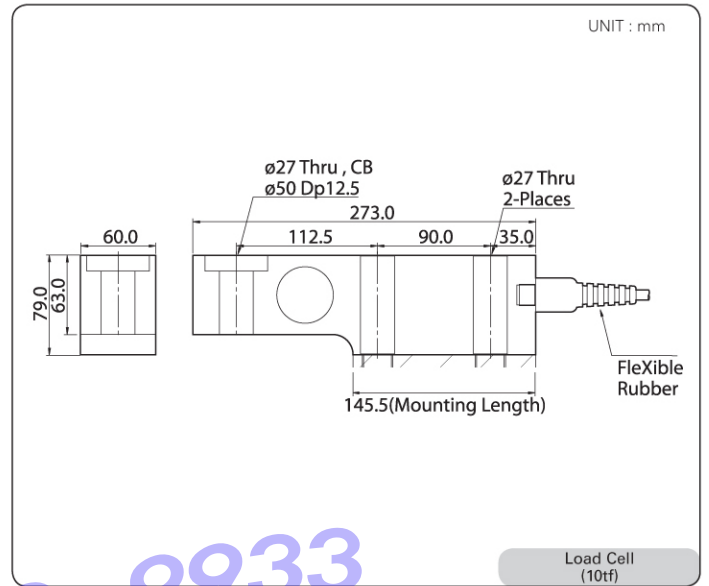
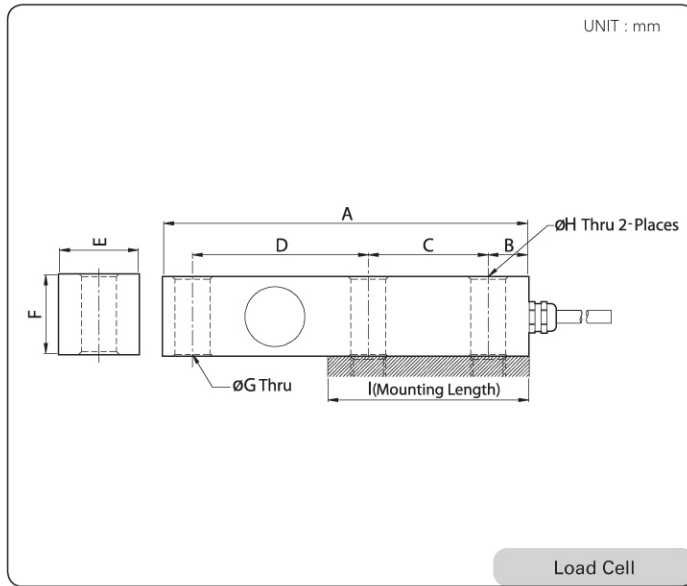

Capa.	A	B	C	D	E	F	G	H	I
250kgf	145.0	20.0	40.0	72.0	34.0	30.0	16.0	14.5	80.0
500kgf									
1tf	205.0	25.0	55.0	105.0	48.0	38.0	20.5	20.5	105.0
2tf									
5tf									

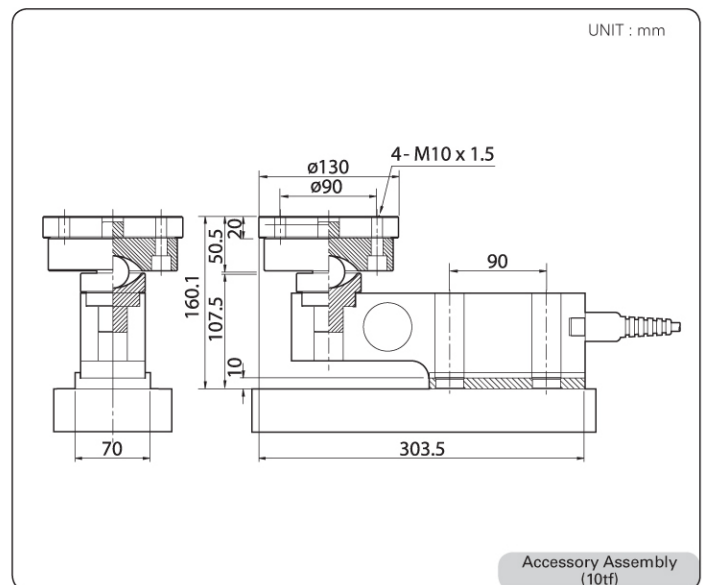
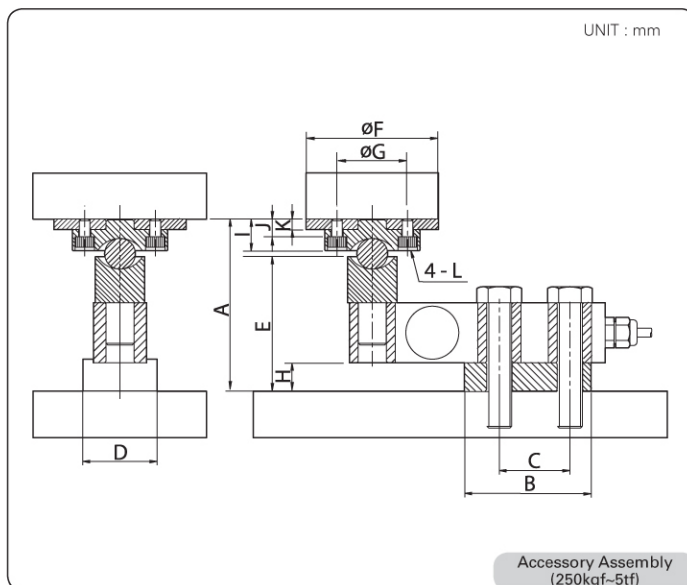

Capa.	A	B	C	D	E	F	G	H	I	J	K	L
250kgf	97.4	72.0	40.0	42.0	76.0	75.0	40.0	16.0	18.0	10.0	6.0	M6 X 1.0
500kgf												
1tf	134.0	100.0	55.0	48.0	84.0	100.0	50.0	16.0	40.0	25.0	15.0	M10 X 1.5
2tf												
5tf												

SINGLE POINT
BENDING & SHEAR
S-BEAM
CANISTER
PANCAKE & MINTURE
TRUCK & TANK WEIGHING
SPECIAL APPLICATION