

LOAD CELL

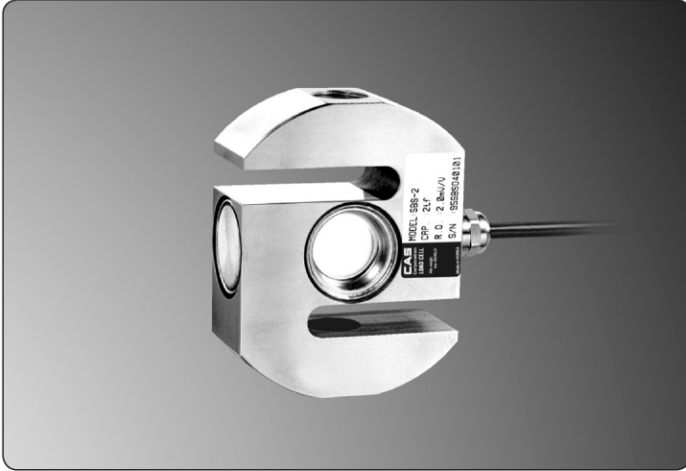

DIMENSION

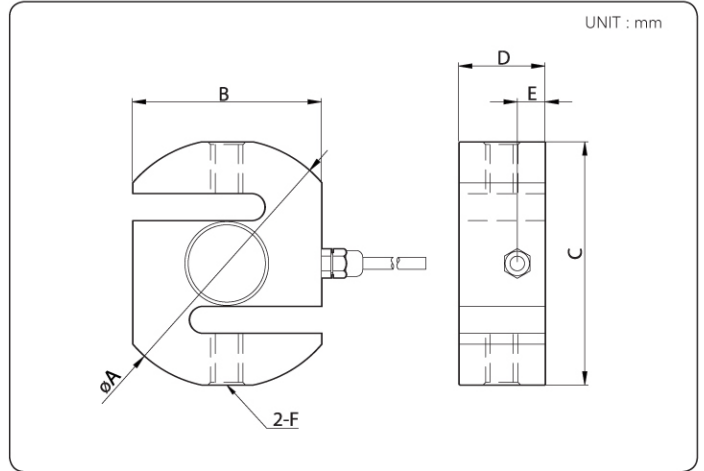

FEATURES

- Stainless steel
- Protection Class IP67
- Option - Exia IICT6
- Tension type load cell

ACCESSORY OPTION

- Rod End (500kg : M12 x 1.75)
- Rod End (1K~2K : M18 x1.5)
- Rod End (5K : M18 x1.5)

Capa.	A	B	C	D	E	F
500						M12 X 1.75
1000	92	70	90	32	10.3	M18 X 1.5
2000						
5000	130	100	120.0	45.0	15.0	M24 X 2.0

SPECIFICATION

Max. Capacity (Rated Load)	kgf	500, 1K, 2K, 5K
Rated Output	mV/V	2.0 ± 0.002
Zero Balance	mV/V	0.0 ± 0.02
Accuracy Class	-	-
Non-Linearity	% R.O.	0.05
Hysteresis	% R.O.	0.05
Combined Error	% R.O.	0.05
Repeatability	% R.O.	0.01
Creep for 30min.	% R.O.	0.03
Return for 30min.	% R.O.	0.03
Resolution	-	≤1/2000
Division	mV/V	0.001
Temperature Effect on	-	-
_Zero Value	% / 10°C	0.03
_Output Value	% / 10°C	0.014
Excitation	-	-
_Recommended	V	10
_Maximum	V	15
Resistance	-	-
_Input	Ω	400 ± 25
_Output	Ω	350 ± 3.5
_Insulation	MΩ	>2000
Compensated Temperature Range	°C	-10 to +40
Operating Temperature Range	°C	-30 to +80
Material & Plate	-	Stainless Steel (Buffing)
Cable Specification	-	∅5.4 x 4p x 5M (Urethane-Jacket, EXP:Gray)
Safety Overload	% R.L.	150% R.L.
Platform Size	mm	No Platform Type



DIMENSION

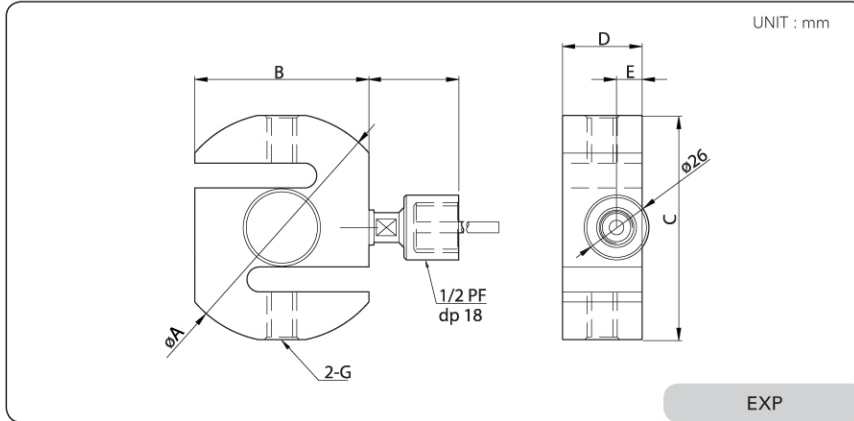

Capa.	A	B	C	D	E	F	G
20	92	70	90	32	10.3	36	M12 X 1.75
50	92	70	90	32	10.3	36	M18 X 1.5
75							
100	130	100	120	45	15	36	M24 X 2.0

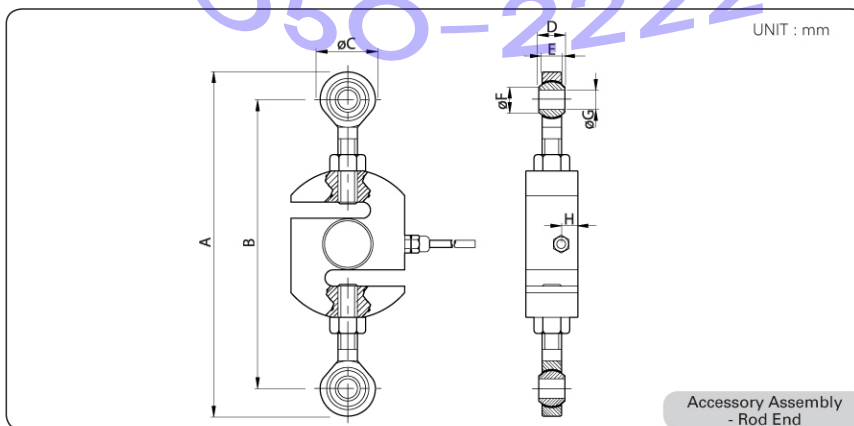

Capa.	A	B	C	D	E	F	G	H
500	212	178	34	16	12	15.4	12	10.3
1000	299.7	239.7	60	23	22	21.9	18	10.3
2000	(Max)	(Max)						
5000	490	388	102	28	27	25.8	22	15

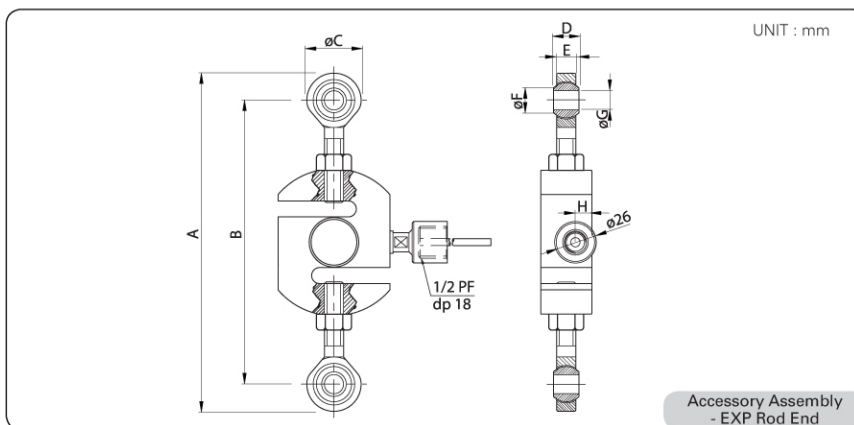

Capa.	A	B	C	D	E	F	G	H
500	212	178	34	16	12	15.4	12	10.3
1000	299.7	239.7	60	23	22	21.9	18	10.3
2000	(Max)	(Max)						
5000	490	388	102	28	27	25.8	22	15